

EXCITATION SYSTEMS

GENERATORS: PART 3

EXCITATION SYSTEMS

---

1.0 OBJECTIVES

The student must be able to:

1. Explain:

- a) The requirements for excitation systems.
- b) How an excitation system is controlled, and the consequences of incorrect control.

2. Explain what is meant by the following:

- a) Reference signal
- b) Feedback signal
- c) Comparator

3. Explain, using the necessary labelled diagrams, an excitation system similar to the one used at your location.

4. a) Explain the function of the field discharge resistor and its associated breaker.
- b) State the consequences of incorrect operation of the resistor and/or its associated breaker.

5. Explain how, at his location, the dc excitation supply is obtained.

6. Explain:

- a) The function of the voltage comparator.
- b) The function of the AVR.
- c) Using block diagrams, how the main generator output voltage is automatically controlled at his location.

## 2.0 INTRODUCTION

This lesson explains the requirements of and the control methods used with small and large generators.

It then describes, in simplified form, the excitation systems used at Pickering A and B and the Bruce A Generating Station.

## 3.0 REQUIREMENTS

An excitation system must have the following features:

### 3.1 Reliability

Lesson 230.22-1 explained that a generator requires excitation to produce an electrical output. If the excitation fails whilst a generator is on load, the magnetic coupling between the rotor and stator will be lost. The generator will no longer produce an electrical output. As the turbine is producing a mechanical output and the generator is not acting as a load, the turbine-generator will speed up. The amount of overspeed will be determined by the ability of the turbine governor to hold the speed to a safe value.

It follows that an excitation system must have a very high level of reliability. When excitation systems are designed, the reliability of each component and the reliability of the electrical supply for the excitation are carefully considered. Because there has been so much development of electrical components, in particular semi-conductors, there are many different designs.

### 3.2 dc Requirements

An excitation system must be able to provide the required dc output to provide the magnetic flux for a generator, under the following conditions:

- a) When the generator is on no load, the excitation system has to provide sufficient flux to cause the generator to produce rated voltage at rated speed.
- b) From no load to full load operation, the excitation current has to be increased to counter-act the effects of armature reaction. Typically, between no load and full load, the excitation current has to be increased by a factor of 2.0 to 2.5, for example 1700 A to 4000 A.

- c) When faults occur on the grid system, due to lightening or other causes, the voltages are depressed or reduced. An excitation system must have a very fast response. It must be able to increase excitation very rapidly (typically within 0.25 seconds) to counter-act these voltage depressions and in turn, quickly restore the main ac generator output voltage to normal.

#### 4.0 TYPICAL EXCITATION SYSTEMS

Small ac generators (less than 1 MW output) have their output provided by dc generators. This excitation is either manually controlled or controlled by a simple Automatic Voltage Regulator (AVR).

Medium-sized ac generators (1 MW to 250 MW) have their excitation provided by dc generators which are controlled by an automatic voltage regulator (AVR).

Because of technical difficulties, associated with large dc generators (see Section 4.3.1 of this lesson), large ac generators (above 250 MW) take their excitation from an ac source. This ac is converted to dc before being applied to the rotor of the main ac generator. The control of this excitation is done by the AVR.

#### 4.1 Excitation Systems For Small ac Generators

Figure 1 shows a system where the output from a dc shunt generator is applied through a control rheostat to the sliprings of the main ac generator.

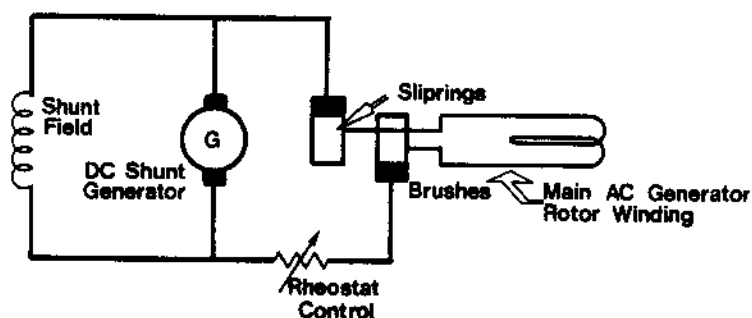

Figure 1: An ac Generator Being Excited Using a dc Shunt Generator

The system shown has four disadvantages. They are:

- a) The field rheostat has no automatic control and therefore has to have constant attention from the operator who will have to adjust the excitation with each change of voltage or load.
- b) There is, in proportion to the ac generator output, a large waste of power in the control rheostat.
- c) In the event of a fault or short circuit in the main generator, there is no method of quickly reducing the main generator field. When a fault occurs in the main generator, if the field is not rapidly reduced to zero, the generator will continue feeding current into the fault and severe damage, due to burning will follow.
- d) The output current from the exciter will vary. This variation is mainly due to the generator rotor windings heating up. As the rotor heats, its resistance increases and for a given excitation supply voltage, the excitation current falls. This fall in excitation current will if not corrected, reduce the output voltage of the generator.

#### 4.2 Excitation Systems for Medium Sized ac Generators

Medium sized ac generators (1 MW to 250 MW) require more than one stage of excitation, see Figure 2. The automatic voltage regulator could be placed in series with the main excitation supply, but because of the much higher currents involved, (up to 1500 A on a 200 MW generator) the components would be large and costly. There would also be a large power loss. Placing the automatic voltage regulator (AVR), in series with the pilot exciter, enables the AVR to control a small current (less than 100 A). The AVR is now much smaller and cheaper and there is a much smaller power loss, typically one hundredth.

4.2.1 The dc pilot exciter gives a constant voltage output. This output is controlled by the AVR and applied to the field of the main dc exciter. The output from the main dc exciter is taken through the field breaker to the main ac generator sliprings.

4.2.2 The comparator compares the voltage produced by the main ac generator with the voltage that is demanded by the control room operator. The voltage produced by the main ac generator is proportionally reduced by the potential transformer and is applied to one side of the comparator.

This signal is called the feedback signal because it is fed back from the output. The other side of the comparator is supplied with the voltage that is set by the control room operator. This signal is known as the reference signal.

If the output voltage of the main generator falls below the voltage setting applied by the operator, the comparator will sense the difference and send a signal to the AVR. The AVR will then raise the field current on the main exciter which will increase its output voltage. The excitation will now be increased, enabling the generator to produce the required output voltage. Similarly, if the main generator output voltage rises, the comparator will once again sense the difference. The AVR will lower the exciter output which will reduce the main generator output voltage to the required value.

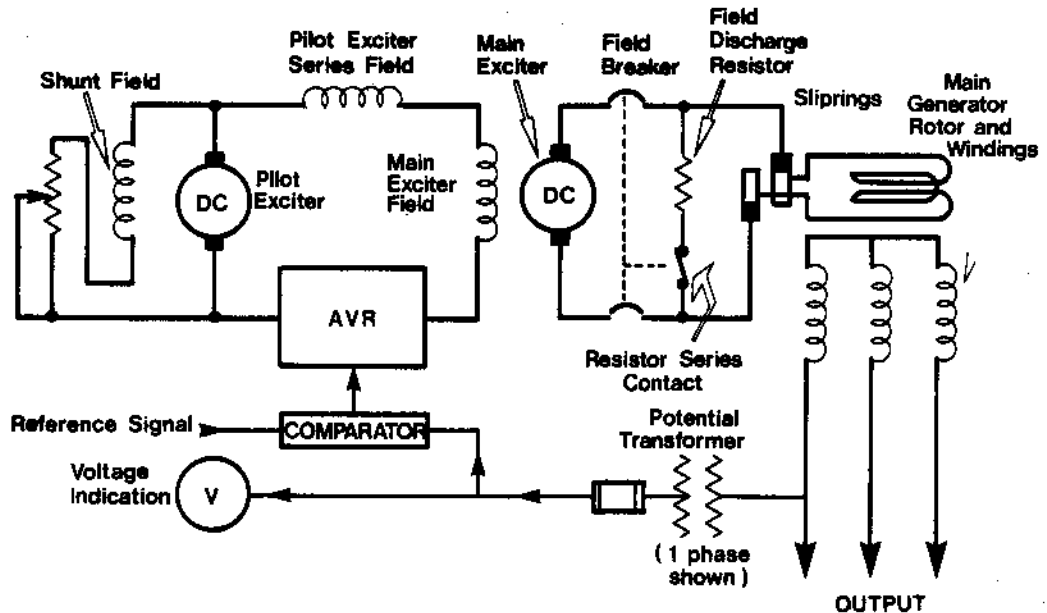

Figure 2: Typical Excitation System for an ac Generator (1 MW to 250 MW).

## 4.2.3

A field circuit breaker and field discharge resistor are used to protect the generator stator and rotor. The field circuit breaker is arranged to trip when a fault occurs in the main generator windings or associated equipment, including the main transformer. Bearing in mind this breaker can open when full current is flowing in the generator rotor windings, opening the breaker under this condition will cause the generator field flux to decay rapidly. As the generator rotor has many turns, a rapid change in flux will cause a very large voltage to be induced in the rotor windings because of

$$e = N \frac{d\phi}{dt}$$

The value of induced voltage may be sufficient to cause a flash over in the generator rotor, at the sliprings or on other parts of the excitation system. To guard against this, the field discharge resistor series contact closes and switches the field discharge resistor into circuit just before the main field breaker contacts open. This resistor safely dissipates the energy from the rotor and limits the value of induced voltage to a safe value. It should be noted that the field discharge resistor series contact:

- a) closes before the breaker main contacts open, and
- b) opens after the breaker main contacts close.

Therefore at all times, the breaker contacts are closed and/or the field discharge resistor contact is closed. The rotor is never left open circuited.

### 4.3 Excitation systems for Large ac Generators

4.3.1 Generators of 250 MW output and above do not use dc generators for their excitation because:

- a) the dc generators would be too bulky and too expensive, compared with ac exciters and rectifiers.
- b) more maintenance is required with dc generators (compared with ac generators) and consequently their reliability is usually lower.
- c) excitation schemes using dc generators have a slow response due to the inductance of their windings opposing changes in field currents and hence flux and output voltage. Because of this, they are unsuitable for use where fast response is required.

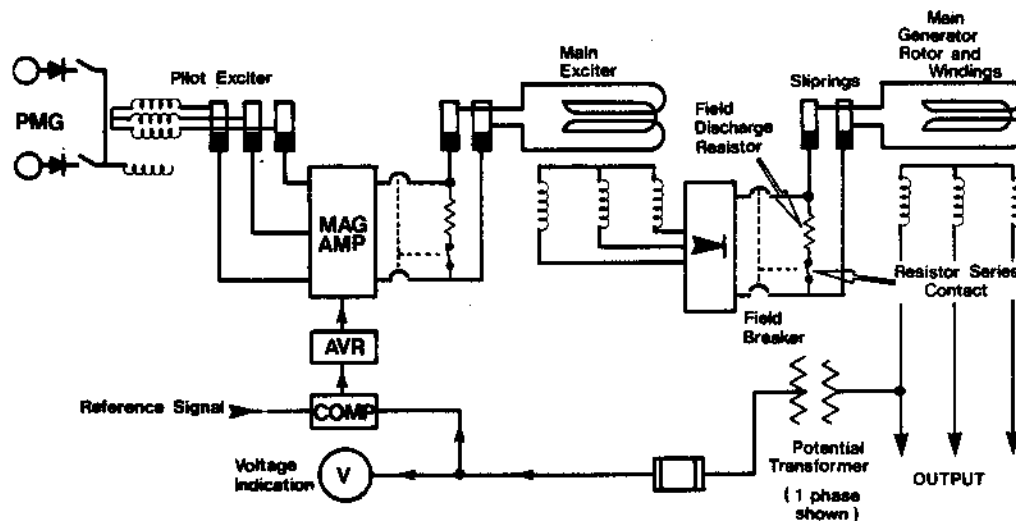

**Figure 3: Simplified Version of the Pickering Excitation System**

4.3.2 Excitation systems using rectified ac have been developed. These systems have fast response and large outputs. Figure 3 shows a simplified version of the Pickering excitation system. Note that the system is basically the same as the one shown in Figure 2, with the exception that ac pilot and main exciters are used.

The Permanent Magnet Generator (PMG) output is rectified and produces the field for the pilot exciter. This dc output from the pilot exciter and rectifier is fed to the main exciter rotor via the magnetic amplifier. The magnetic amplifier rectifies the output from the pilot exciter and at the same time controls the main exciter rotor current and flux. The ac output from the main exciter is rectified and fed to the main generator rotor via the field breaker.

The comparator is supplied with the same signals as in Figure 2. The comparator controls the AVR which in turn controls the magnetic amplifier.

This type of excitation system has two main disadvantages:

- a) it is complicated and has many moving parts consisting of the permanent magnetic generator (PMG) the pilot exciter and the main exciter. There are three sets of sliprings and brushes, all of which require regular on load maintenance.
- b) its response is faster than if dc exciters have been used. It is not as fast as the excitation system used at Bruce A NGS. The Bruce A system is described in the next section.

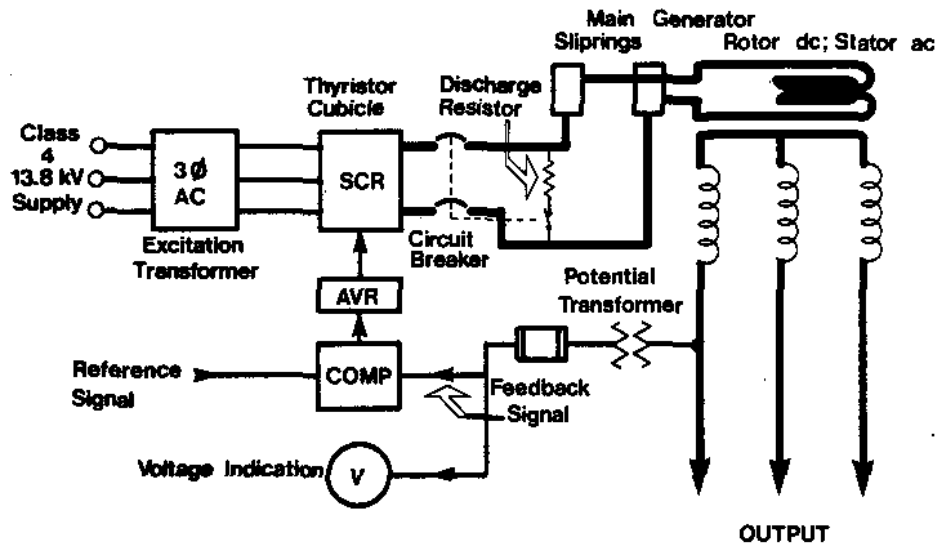

Figure 4: Simplified Version of the Bruce 'A' Excitation



4.3.3

To overcome the two problems stated in 4.3.2 a) and 4.3.2 b) the excitation system shown in Figure 4 has been developed for use at Bruce A NGS. On each unit, instead of using a shaft driven PMG, pilot exciter and main exciter, the excitation supply is taken from the 13.8 kV Class 4 system, via the excitation transformer. The output from the transformer is converted on dc and at the same time controlled using thyristors (silicon controlled rectifiers). These silicon controlled rectifiers are controlled by the AVR. This results in a much simpler system having fewer moving parts. The only disadvantage is that any fluctuations in the Class 4 supply voltage must be compensated for by the action of the AVR and thyristors. In practice, this system has given excellent results.

ASSIGNMENT

1. What three features must an excitation system dc output provide?
2. What are the disadvantages of using a dc generator with no AVR to excite a large generator?
3. Explain what is meant by "reference" and "feedback" signals in an excitation scheme. Taking the Bruce A or Pickering A excitation system, explain the sequence of events which occur when the main generator terminal voltage is lowered by a lightning fault striking a nearby transmission line.
4. Explain the function of the field discharge resistor and the probable consequences of the discharge resistor becoming open circuited.
5. Given a simplified schematic diagram of either the Pickering or Bruce A excitation system, state and explain the function of the principal components.

J.R.C. Cowling